

**ROUTINE**

The MWO effective date is 1 December 1997 and the completion date is 30 November 2001.

**MODIFICATION WORK ORDER**

**MODIFICATION OF HOWITZER, MEDIUM,  
SELF-PROPELLED: 155MM, M109A6  
(NSN 2350-01-305-0028) (EIC: 3FC)**

**Headquarters, Department of the Army, Washington, D.C.  
1 SEPTEMBER 1998**

REPORTING OF ERRORS AND RECOMMENDING IMPROVEMENTS You can help improve this MWO. If you find any mistakes or if you know of a way to improve these procedures, please let us know. Mail your letter or DA Form 2028, Recommended Changes to Publications and Blank Forms, direct to Director, Armament and Chemical Acquisition and Logistics Activity, ATTN: AMSTA-AC-NMLI, Rock Island, IL 61299-7630. A reply will be provided to you.

DISTRIBUTION STATEMENT A. This publication is approved for public release; distribution is unlimited.

1. **PURPOSE.** This MWO prescribes procedures for installing a segment board cleaning mechanism. The segment board cleaning mechanism is a permanently installed assembly that makes cleaning the segment board easier.
2. **PRIORITY.** This modification is classified ROUTINE.
3. **END ITEM(S) OR SYSTEM(S) TO BE MODIFIED.** See Table 1.

*Table 1. End Item or System to be Modified.*

NOMENCLATURE	NSN	PART NO.	MODEL	CAGEC	SERIAL NO RANGE
Howitzer, Medium, Self-Propelled: 155 MM	2350-01-305-0028	12553195	M109A6	19200	1-645

4. **MODULE(S) (COMPONENTS, ASSEMBLIES, SUBASSEMBLIES, BOARDS, AND CARD(S) TO BE MODIFIED).** Not applicable.
5. **PARTS TO BE MODIFIED.** The parts listed in Table 2, whether installed or in depot stock, shall be modified. Stocked parts shall be modified prior to issue and shall be marked so that it can be easily determined that modification has been accomplished. The electrical shield part number and NSN change when the electrical shield is modified.

Table 2. Parts to be Modified.

NOMENCLATURE	NSN	CAGEC	PART NO.	ITEM NO.
Shield, Electrical	5999-01-324-2208	19200	12910552	10

**6. APPLICATION.**

a. Time Compliance Schedule: The MWO effective date is 1 December 1997 and the completion date is 30 November 2001.

b. Level of Maintenance: Unit maintenance is the lowest level of maintenance authorized to apply this MWO.

c. Work Force and Man-hour Requirements.

## REQUIREMENTS

WORK FORCE/SKILLS	MAN-HOURS	MAN-HOUR W/O DISASSEMBLY
Armament Repairer (MOS. 45D)	1.25 hour	1.00 hour

d. MWOs to be Applied Prior to or Concurrently with this MWO. None.

e. Additional Information. None.

**7. TECHNICAL PUBLICATIONS AFFECTED/CHANGED.**

TM 9-2350-314-10  
TM 9-2350-314-20-2  
TM 9-2350-314-24P-2

**8. MWO KIT(S)/PART(S) AND THEIR DISPOSITION.**

a. Kit(s)/Part(s) Needed to Apply the MWO. See Table 3.

Table 3. Kits/Parts Required.

NOMENCLATURE	NSN	CAGEC	PART NO.	QTY	ITEM NO.
Washer, Lock	5310-00-209-0786	96906	MS35335-33	12	2,5,12
Washer, Lock	5310-00-584-5272	96906	MS35338-48	1	18
Washer, Lock	5310-00-637-9541	96906	MS35338-46	1	26
Lifting Assembly	TBD	19200	12984448	1	32
Shield, Electrical	TBD	19200	12984447	1	33
Screw	5305-01-309-4781	96906	MS24678-42	4	35
Washer, Flat	5310-01-280-5796	96906	MS27183-57	4	36
Cleaning Block Assembly	TBD	19200	12984454	1	37

b. Contents of MWO Kits. Not applicable.

c. Bulk and Expendable Material. See Table 4.

Table 4. Bulk and Expendable Material

NOMENCLATURE	NSN	CAGEC	PART NO.
Alcohol, Isopropyl	6810-01-190-2538	81348	TT-1-735

d. Parts Disposition. Parts that are not used on the modified howitzer are listed in Table 5. Follow special disposition instructions provided by the item manager.

Table 5. Parts Disposition

NOMENCLATURE	NSN	CAGEC	PART NO.	QTY	ITEM NO.
Washer, Lock	5310-00-209-0786	96906	MS35335-33	12	2,5,12
Shield, Electrical	5999-01-324-2208	19200	12910552	1	10
Washer, Lock	5310-00-584-5272	96906	MS35338-48	1	18
Washer, Lock	5310-00-637-9541	96906	MS35338-46	1	26

9. SPECIAL TOOLS; TOOL KITS; JIGS; TEST, MEASUREMENT, AND DIAGNOSTIC EQUIPMENT. None.

10. MODIFICATION PROCEDURES.

#### WARNING

**Use caution when rotating-the turret to avoid personal injury and/or equipment damage.**

a. Setup.

(1) Release the gun tube from the travel lock. Traverse the turret counterclockwise until the traverse lock is positioned directly above the non-hinged edge of the crew compartment door.

(2) Switch the MASTER power switch to the OFF position and disconnect the battery ground leads.

b. Removal of the Electrical Shield.

#### WARNING

**Verify that the MASTER power switch is in the OFF position and the battery ground leads are disconnected. Failure to switch the MASTER power switch OFF and disconnect the battery ground leads can lead to serious personal injury.**

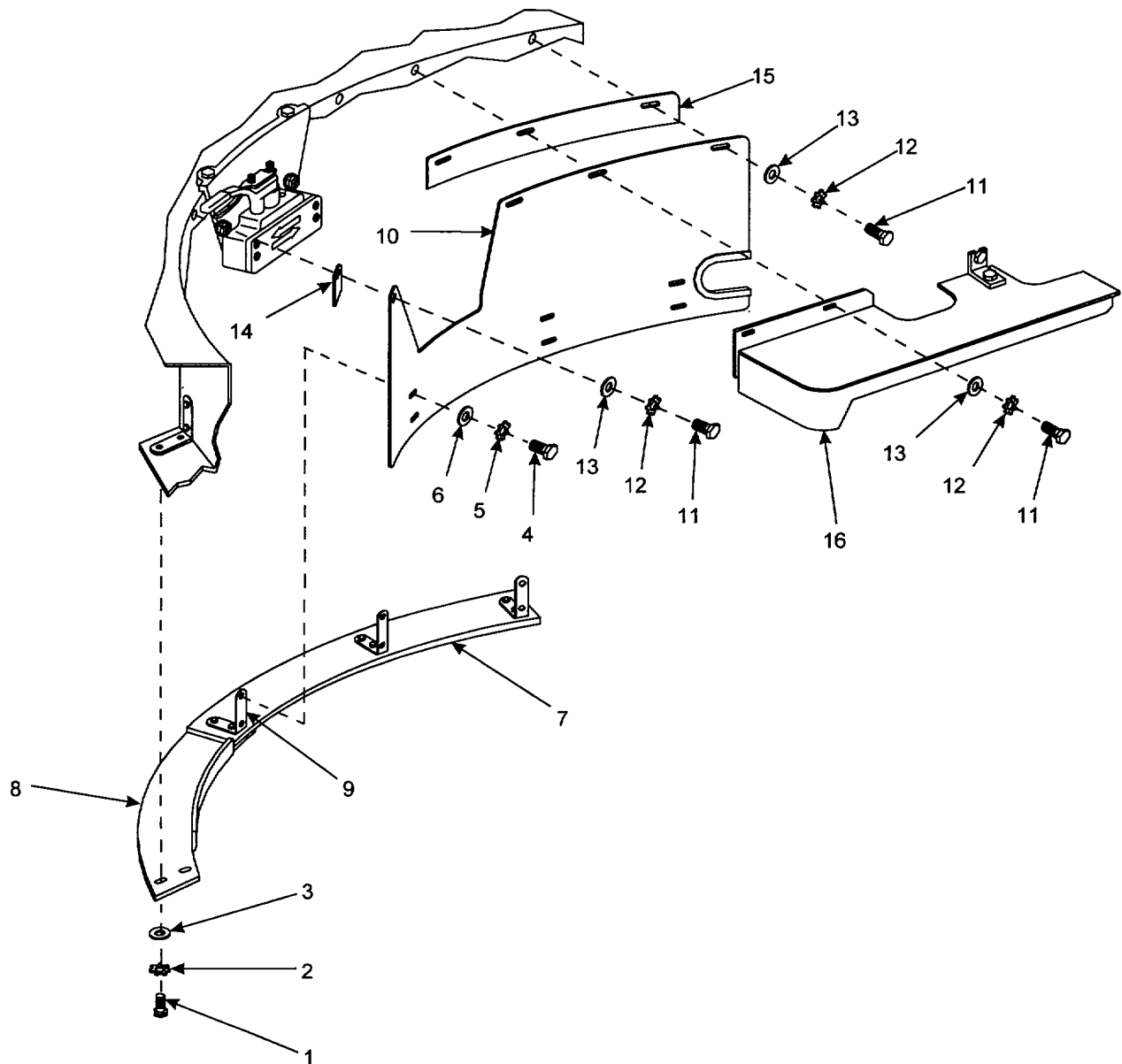

(1) Remove two screws (1), two lock washers (2), and two flat washers (3). Set the two lock washers aside for disposition per paragraph 8.

(2). Remove six screws (4), six lock washers (5), and six flat washers (6) that secure electrical shield (7), electrical shield (8) and three hooks (9) to electrical shield (10). Remove, but do not disassemble electrical shield (7), electrical shield (8), and three hooks (9). Set the six lock washers aside for disposition per paragraph 8.

(3). Remove four screws (11), four lock washers (12), four flat washers (13), electrical shield (10), spacer (14), and spacer (15). The electrical shield slides down from behind mechanical drive guard (16) without removing the mechanical drive guard. Set the four lock washers and the electrical shield aside for disposition per paragraph 8.

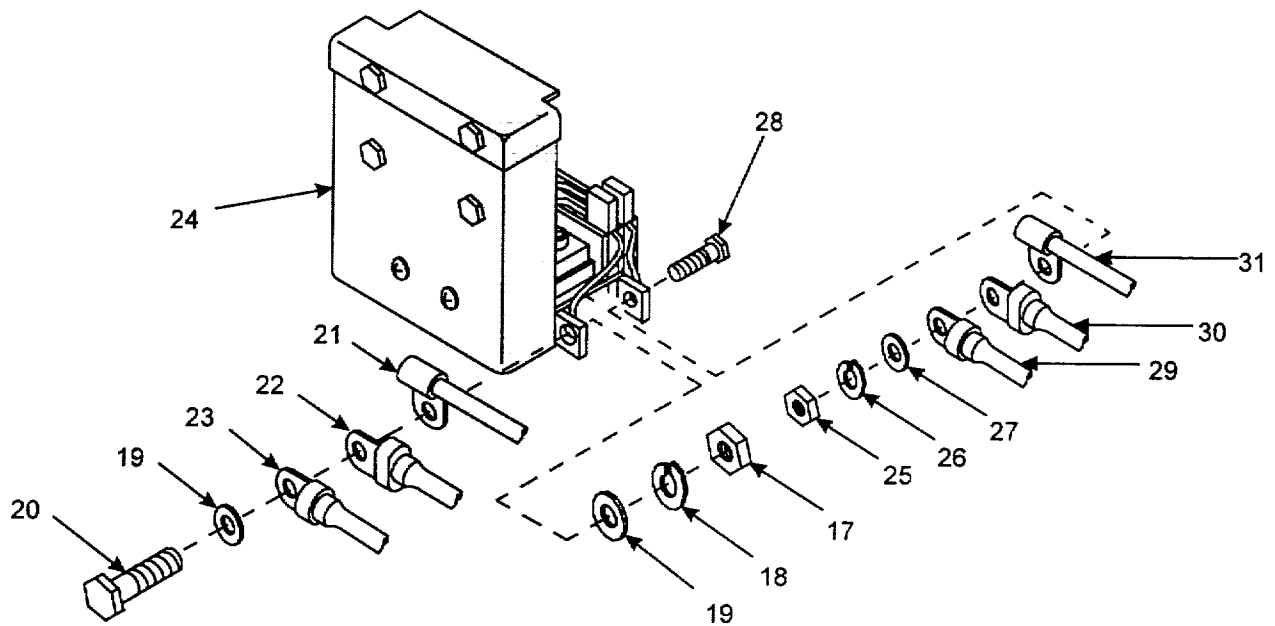

(4) Remove nut (17), lock washer (18), two flat washers (19), screw (20), and three electrical leads (21, 22, 23) from brush block #6 (24). Remove nut (25), lock washer (26), flat washer (27), screw (28), and three electrical leads (29, 30, 31) from brush block #6 (24). Set the two lock washers aside for disposition per paragraph 8.

c. Installation of the Segment Board Cleaning Mechanism.

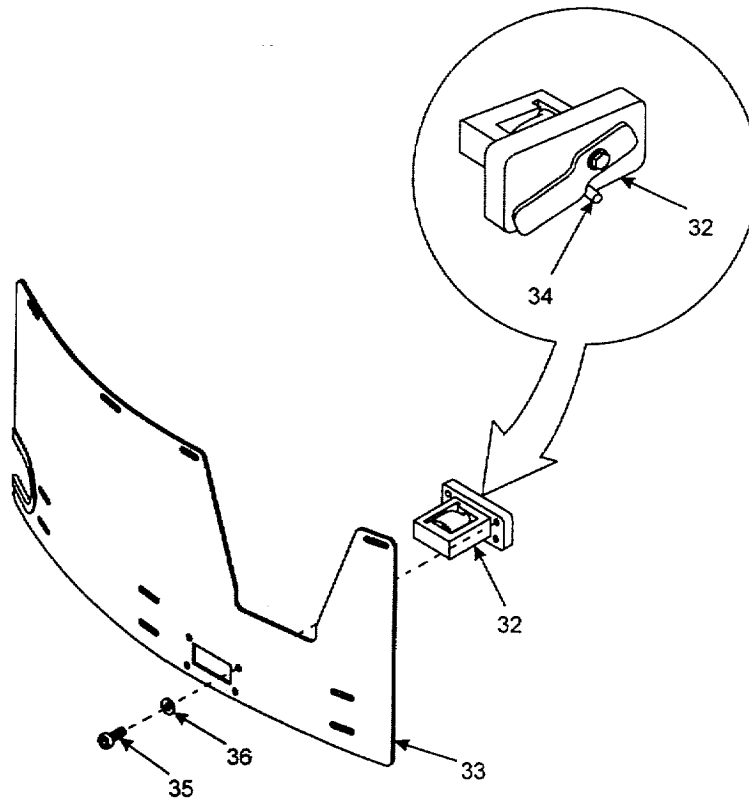

**NOTE**

**When installing lifting assembly (32) on modified electrical shield (33), make sure stop pin (34) is near the bottom of the lifting assembly.**

(1) Fasten lifting assembly (32) to modified electrical shield (33) with four screws (35) and four flat washers (36). The modified electrical shield has a rectangular cutout and four extra screw holes to accommodate the lifting assembly.

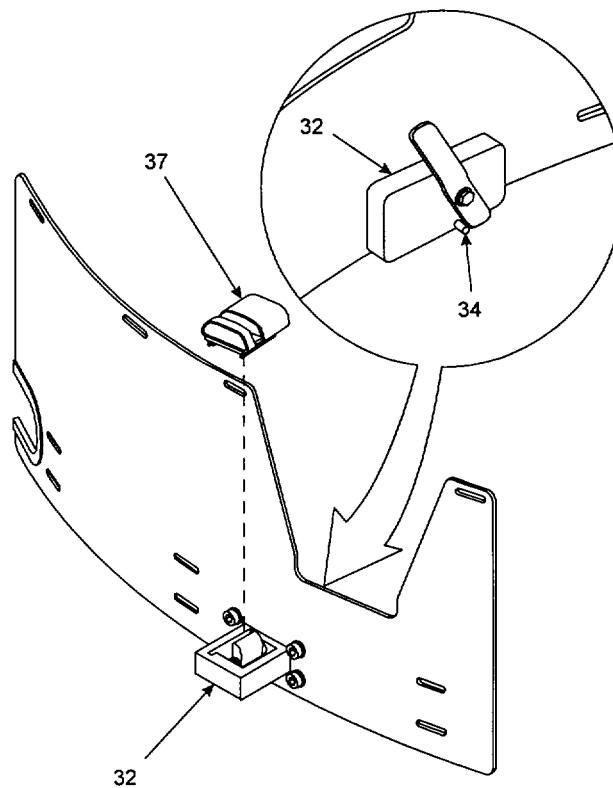

(2) Rotate the handle on lifting assembly (32) clockwise so it contacts stop pin (34).

(3) Insert cleaning block assembly (37) into lifting assembly (32).

(4) Release the handle on lifting assembly (32). It should rotate counterclockwise; back to its original position.

d. Installation of the Electrical Shield.

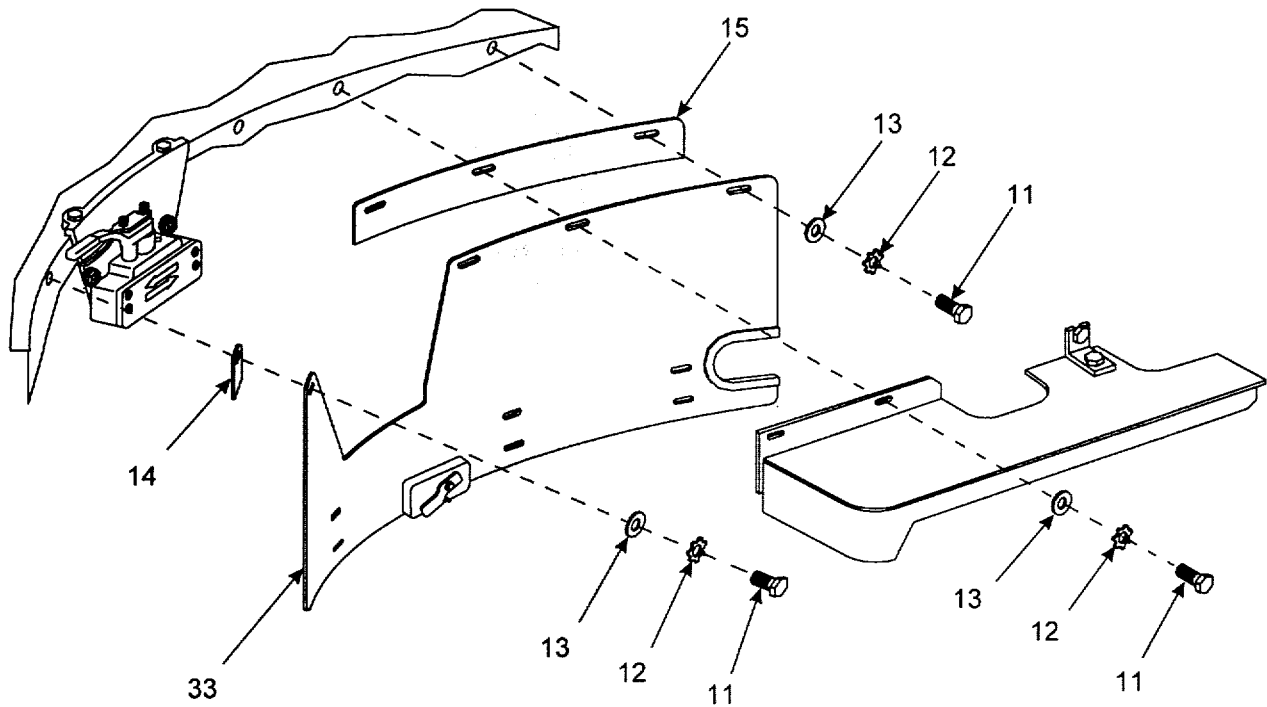

(1) Slide modified electrical shield (33) upward, into place behind mechanical drive guard (16).

(2) Fasten electrical shield (33), spacer (14) and spacer (15) to the cab with four screws (11), four new lock washers (12), and four flat washers (13).

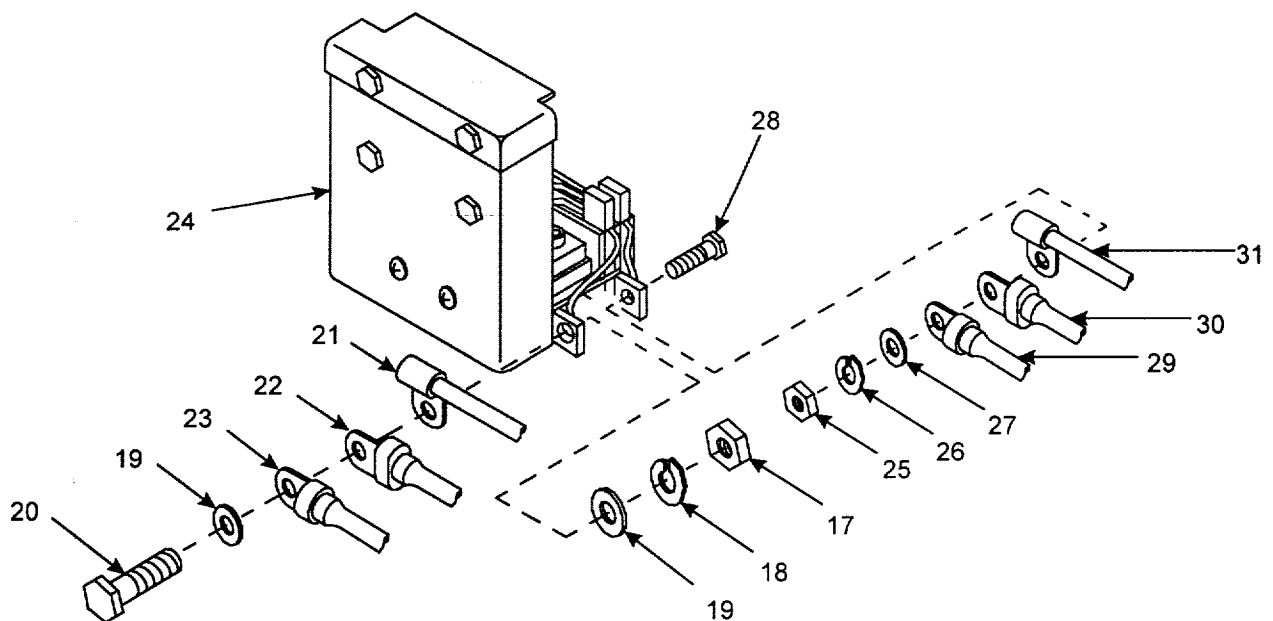

(3) Reconnect three electrical leads (21, 22, 23), to brush block #6 (24) with screw (20), two flat washers (19), new lock washer (18), and nut (17). Reconnect three electrical leads (29, 30, 31), to brush block #6 (24) with screw (28), flat washer (27), new lock washer (26), and nut (25).

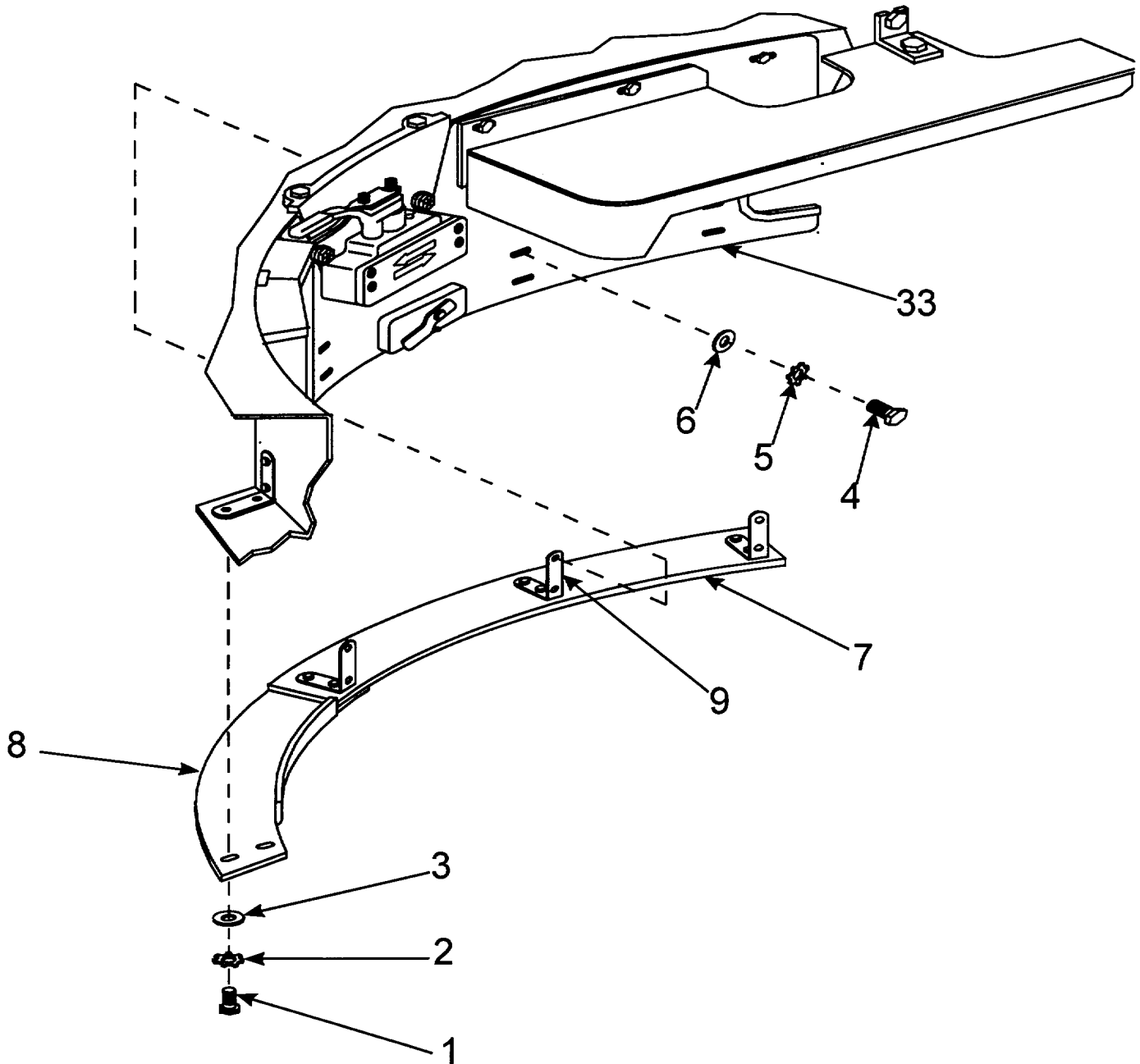

(4) Secure electrical shield (7), electrical shield (8), and three hooks (9) to electrical shield (33) with six screws (4), six new lock washers (5), and six flat washers (6). Install two screws (1), two new lock washers (2), and two flat washers (3).

**11. CALIBRATION REQUIREMENTS.** Not applicable.

**12. WEIGHT AND BALANCE DATA.** Weight and balance are not significantly affected.



**13. QUALITY ASSURANCE REQUIREMENTS.****WARNING**

**Serious personal injury may result if the segment boards are cleaned with the battery ground leads connected and the MASTER power switch ON.**

- a. With the battery ground leads still disconnected and the MASTER power switch still in the OFF position, clear any loose debris from eight brush blocks and two segment boards by hand.
- b. Operate the segment board cleaning mechanism in accordance with TM 9-2350-314-20-2-2, paragraph 23-3.c, steps 22 through 28.
- c. Verify that the cleaning pads contact the segment board when the handle on the lifting assembly is rotated clockwise. Verify that the cleaning pads do not contact or only lightly touch the segment board when the handle on the lifting assembly is released.
- d. Reconnect the battery ground leads.

**14. RECORDING AND REPORTING OF THE MODIFICATION.**a. Records and Reports.

- (1). Record the modification on DA Form 2408-5, Equipment Modification Record, IAW DA Pamphlet 738-750, The Army Maintenance Management System (TAMMS).
- (2). Complete DA Form 2407, Maintenance Request, IAW DA Pamphlet 738-750, TAMMS. Forward the NMP copy to: Director, Armament and Chemical Acquisition and Logistics Activity, ATTN: AMSTA-AC-NMR, Rock Island, IL 61299-7630. Forward the organizational copy as directed by the local commander.

b. Marking Equipment. Not applicable.c. Identification Data. Not applicable.

15. **MATERIEL CHANGE (MC) NUMBER.** This MWO is authorized by MC Number 1-81-05-1002.

16. **MODIFICATION IDENTIFICATION.** This modification has been performed if the segment board cleaning mechanism is installed below the traverse lock.

By Order of the Secretary of the Army:

Official:



JOEL B. HUDSON

*Administrative Assistant to the  
Secretary of the Army*

05029

DENNIS J. REIMER  
*General, United States Army  
Chief of Staff*

DISTRIBUTION:

To be distributed in accordance with the initial distribution number (IDN) 372489 requirements for MWO 9-2350-314-20-10.

RECOMMENDED CHANGES TO EQUIPMENT TECHNICAL PUBLICATIONS



THEN...JOT DOWN THE  
DOPE ABOUT IT ON THIS FORM.  
CAREFULLY TEAR IT OUT, FOLD IT  
AND DROP IT IN THE MAIL.

SOMETHING WRONG WITH PUBLICATION

FROM: (PRINT YOUR UNIT'S COMPLETE ADDRESS)

DATE SENT

PUBLICATION NUMBER

PUBLICATION DATE

PUBLICATION TITLE

BE EXACT PIN-POINT WHERE IT IS

PAGE  
NO.

PARA-  
GRAPH

FIGURE  
NO.

TABLE  
NO.

IN THIS SPACE, TELL WHAT IS WRONG  
AND WHAT SHOULD BE DONE ABOUT IT.

TEAR ALONG PERFORATED LINE

PRINTED NAME, GRADE OR TITLE AND TELEPHONE NUMBER

SIGN HERE

# THE METRIC SYSTEM AND EQUIVALENTS

## WEIGHT MEASURE

1 Centimeter = 10 Millimeters = 0.01 Meters = 0.3937 Inches  
 1 Meter = 100 Centimeters = 1000 Millimeters = 39.37 Inches  
 1 Kilometer = 1000 Meters = 0.621 Miles

## WEIGHTS

1 Gram = 0.001 Kilograms = 1000 Milligrams = 0.035 Ounces  
 1 Kilogram = 1000 Grams = 2.2 lb.  
 1 Metric Ton = 1000 Kilograms = 1 Megagram = 1.1 Short Tons

## LIQUID MEASURE

1 Milliliter = 0.001 Liters = 0.0338 Fluid Ounces  
 1 Liter = 1000 Milliliters = 33.82 Fluid Ounces

## SQUARE MEASURE

1 Sq. Centimeter = 100 Sq. Millimeters = 0.155 Sq. Inches  
 1 Sq. Meter = 10,000 Sq. Centimeters = 10.76 Sq. Feet  
 1 Sq. Kilometer = 1,000,000 Sq. Meters = 0.386 Sq. Miles

## CUBIC MEASURE

1 Cu. Centimeter = 1000 Cu. Millimeters = 0.06 Cu. Inches  
 1 Cu. Meter = 1,000,000 Cu. Centimeters = 35.31 Cu. Feet

## TEMPERATURE

$5/9(^{\circ}\text{F} - 32) = ^{\circ}\text{C}$   
 212° Fahrenheit is equivalent to 100° Celsius  
 90° Fahrenheit is equivalent to 32.2° Celsius  
 32° Fahrenheit is equivalent to 0° Celsius  
 $9/5^{\circ}\text{C} + 32 = ^{\circ}\text{F}$

## APPROXIMATE CONVERSION FACTORS

TO CHANGE	TO	MULTIPLY BY
Inches	Centimeters	2.540
Feet	Meters	0.305
Yards	Meters	0.914
Miles	Kilometers	1.609
Square Inches	Square Centimeters	6.451
Square Feet	Square Meters	0.093
Square Yards	Square Meters	0.836
Square Miles	Square Kilometers	2.590
Acres	Square Hectometers	0.405
Cubic Feet	Cubic Meters	0.028
Cubic Yards	Cubic Meters	0.765
Fluid Ounces	Milliliters	29.573
its	Liters	0.473
arts	Liters	0.946
allons	Liters	3.785
Ounces	Grams	28.349
Pounds	Kilograms	0.454
Short Tons	Metric Tons	0.907
Pound-Feet	Newton-Meters	1.356
Pounds per Square Inch	Kilopascals	6.895
Miles per Gallon	Kilometers per Liter	0.425
Miles per Hour	Kilometers per Hour	1.609

TO CHANGE	TO	MULTIPLY BY
Centimeters	Inches	0.394
Meters	Feet	3.280
Meters	Yards	1.094
Kilometers	Miles	0.621
Square Centimeters	Square Inches	0.155
Square Meters	Square Feet	10.764
Square Meters	Square Yards	1.196
Square Kilometers	Square Miles	0.386
Square Hectometers	Acres	2.471
Cubic Meters	Cubic Feet	35.315
Cubic Meters	Cubic Yards	1.308
Milliliters	Fluid Ounces	0.034
Liters	Pints	2.113
Liters	Quarts	1.057
ers	Gallons	0.264
ms	Ounces	0.035
ograms	Pounds	2.205
Metric Tons	Short Tons	1.102
Newton-Meters	Pounds-Feet	0.738
Kilopascals	Pounds per Square Inch	0.145
ometers per Liter	Miles per Gallon	2.354
ometers per Hour	Miles per Hour	0.621

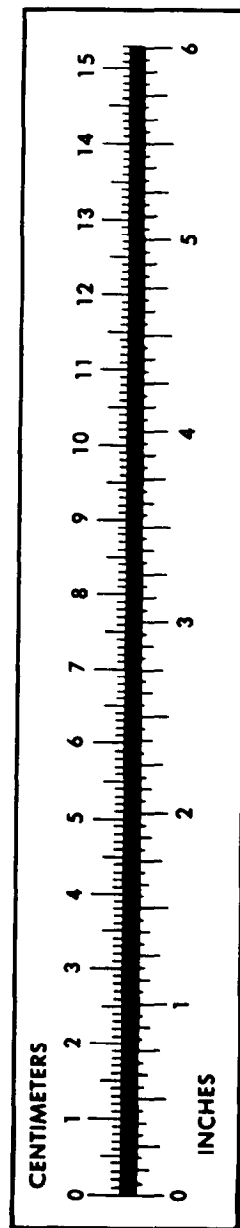

**PIN: 076728-000**